

GCSE Mathematics

Practice Tests: Set 16

Paper 2H/3H (Calculator)

Time: 1 hour 30 minutes

You should have: Ruler graduated in centimetres and millimetres, protractor, pair of compasses, pen, HB pencil, eraser, calculator. Tracing paper may be used.

Instructions

- Use **black** ink or ball-point pen.
- **Fill in the boxes** at the top of this page with your name, centre number and candidate number.
- Answer **all** questions.
- Answer the questions in the spaces provided
– *there may be more space than you need.*
- **Calculators may not be used.**
- Diagrams are NOT accurately drawn, unless otherwise indicated.
- You must **show all your working out.**



Information

- The total mark for this paper is 80
- The marks for **each** question are shown in brackets
– *use this as a guide as to how much time to spend on each question.*

Advice

- Read each question carefully before you start to answer it.
- Keep an eye on the time.
- Try to answer every question.
- Check your answers if you have time at the end.

Answer ALL questions.

Write your answers in the spaces provided.

You must write down all the stages in your working.

- 1 A, B and C are points on a circle with centre O .

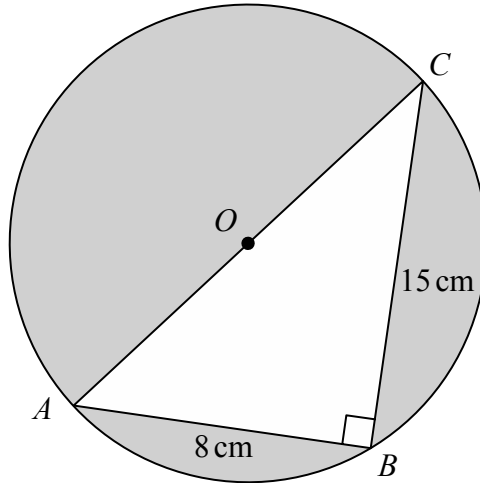

Diagram NOT accurately drawn

AOC is a diameter of the circle.

$AB = 8 \text{ cm}$ $BC = 15 \text{ cm}$

Angle $ABC = 90^\circ$

Work out the total area of the regions shown shaded in the diagram.
Give your answer correct to 3 significant figures.

..... cm^2

(Total for Question 1 is 5 marks)

- 2 The table gives information about the speeds, in kilometres per hour, of 80 motorbikes as each pass under a bridge.

| Speed (s kilometres per hour) | Frequency |
|-------------------------------------|-----------|
| $40 < s \leq 50$ | 10 |
| $50 < s \leq 60$ | 16 |
| $60 < s \leq 70$ | 19 |
| $70 < s \leq 80$ | 23 |
| $80 < s \leq 90$ | 12 |

- (a) Write down the modal class.

.....
(1)

- (b) Work out an estimate for the mean speed of the motorbikes as they pass under the bridge.
Give your answer correct to 3 significant figures.

..... kilometres per hour
(4)

(Total for Question 2 is 5 marks)

3 Gladys buys a table for \$465 to sell in her shop.

She sells the table for \$520

- (a) Work out the percentage profit that Gladys makes from the sale of the table.
Give your answer correct to 3 significant figures.

.....%

(3)

Gladys has a sale in her shop.

She decreases all the normal prices by 12%

The normal price of an armchair was \$550

- (b) Work out the sale price of the armchair.

\$.....

(3)

(Total for Question 3 is 6 marks)

- 4 A train takes 6 hours 39 minutes to travel from New Delhi to Kanpur.
The train travels a distance of 429 km.

Work out the average speed of the train.

Give your answer in km/h correct to one decimal place.

..... km/h

(Total for Question 4 is 3 marks)

5 Chen invests 40 000 yuan in a fixed-term bond for 3 years.
The fixed-term bond pays compound interest at a rate of 3.5% each year.

- (a) Work out the value of Chen's investment at the end of 3 years.
Give your answer to the nearest yuan.

..... yuan
(3)

Wang invested P yuan.
The value of his investment decreased by 6.5% each year.
At the end of the first year, the value of Wang's investment was 30 481 yuan.

- (b) Work out the value of P .

$P =$
(3)

(Total for Question 5 is 6 marks)

6 Pieter owns a currency conversion shop.

Last Monday, Pieter changed a total of 20 160 rand into a number of different currencies.

He changed $\frac{3}{10}$ of the 20 160 rand into euros.

He changed the rest of the rands into dollars, rupees and francs in the ratios 9 : 5 : 2

Pieter changed more rands into dollars than he changed into francs.

Work out how many more.

..... rand

(Total for Question 6 is 4 marks)

7 Here is isosceles triangle ABC .

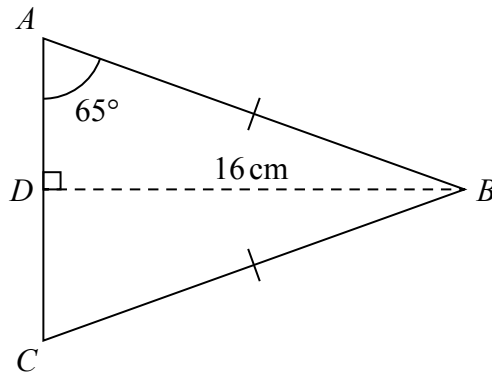

Diagram **NOT** accurately drawn

D is the midpoint of AC and $DB = 16$ cm.

Angle $DAB = 65^\circ$

Work out the perimeter of triangle ABC .

Give your answer correct to one decimal place.

..... cm

(Total for Question 7 is 4 marks)

- 8** There are 5 cocoa pods in a bag.
The mean weight of the 5 cocoa pods is 398 grams.
A sixth cocoa pod is put into the bag.
The mean weight of the 6 cocoa pods is 401 grams.
Work out the weight of the sixth cocoa pod that is put into the bag.

..... grams

(Total for Question 8 is 3 marks)

- 9 The cumulative frequency graph gives information about the weights, in grams, of 90 bags of sweets.

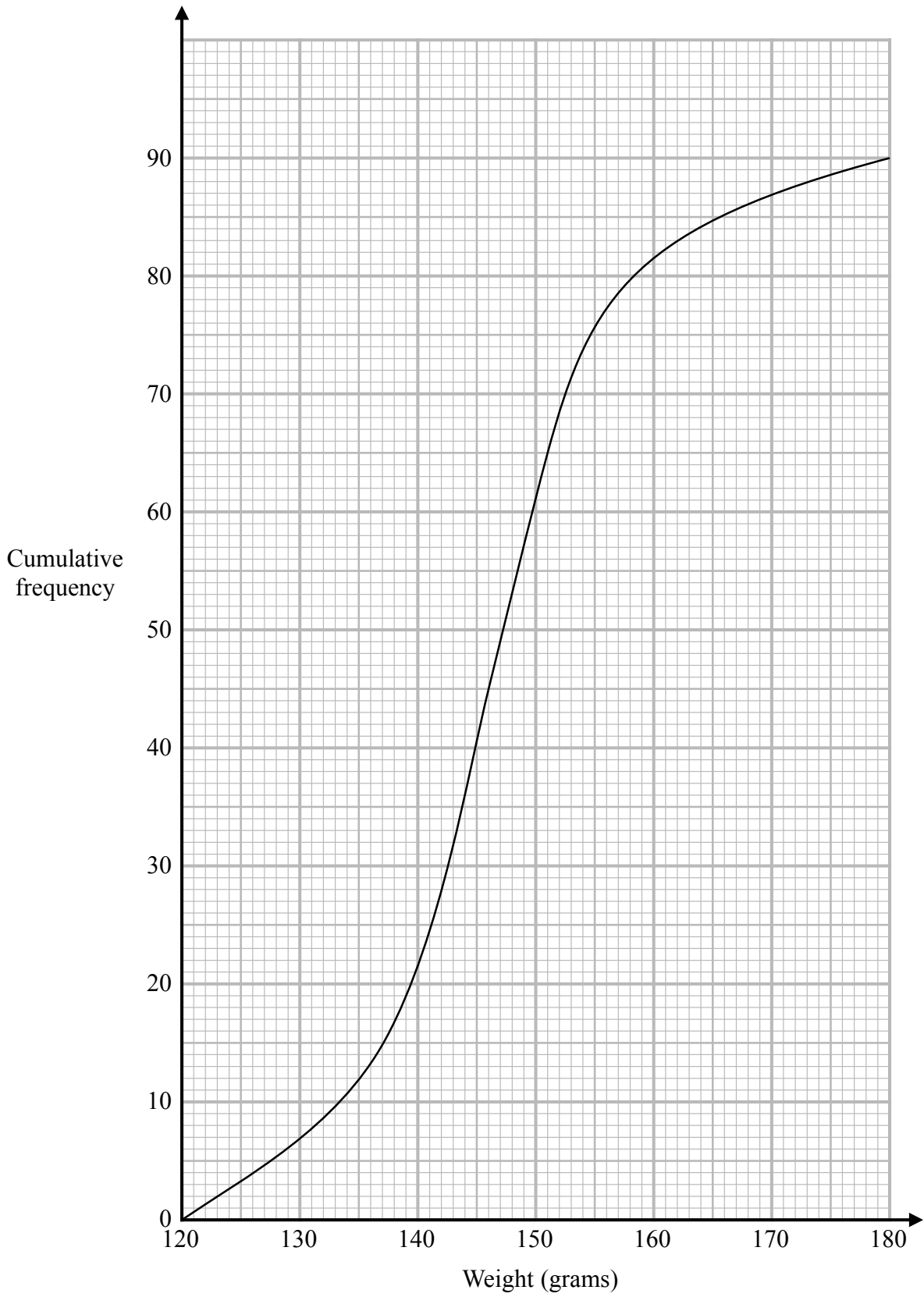

(a) Find an estimate for the median of the weights of these bags of sweets.

..... grams
(2)

Roberto sells the bags of sweets to raise money for charity.

Bags with a weight greater than d grams are labelled large bags and sold for 3.75 euros each bag.

The total amount of money he receives by selling all the large bags is 93.75 euros.

(b) Find the value of d .

$d =$
(3)

(Total for Question 9 is 5 marks)

10 Solve $\frac{9a - 7}{5} - \frac{3a - 7}{4} = 4.55$

Show clear algebraic working.

$a = \dots\dots\dots$

(Total for Question 10 is 3 marks)

11 P, Q, R, S and T are points on a circle with centre O .

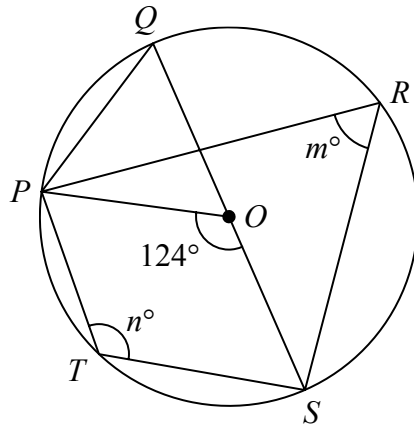

Diagram **NOT** accurately drawn

QOS is a diameter of the circle.

angle $POS = 124^\circ$

angle $PRS = m^\circ$

angle $PTS = n^\circ$

(a) Find the value of

(i) m

.....

(ii) n

.....

(2)

(b) Find the size of angle QPO .

.....^o

(1)

(Total for Question 11 is 3 marks)

12 $a = \frac{v - u}{t}$

$v = 9.6$ correct to 1 decimal place

$u = 3.8$ correct to 1 decimal place

$t = 1.84$ correct to 2 decimal places

Calculate the upper bound for the value of a .

Give your answer as a decimal correct to 2 decimal places.

Show your working clearly.

.....
(Total for Question 12 is 3 marks)

- 13 The region, shown shaded in the diagram, is a path.

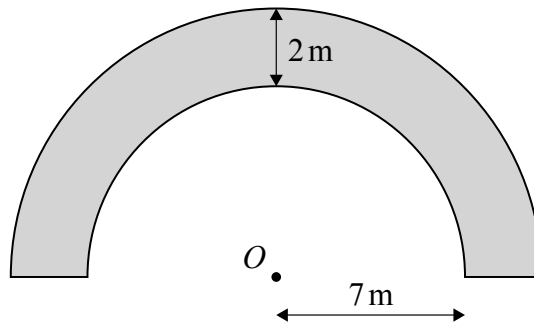

Diagram **NOT**
accurately drawn

The boundary of the path is formed by two semicircles, with the same centre O , and two straight lines.

The inner semicircle has a radius of 7 metres.

The path has a width of 2 metres.

Work out the perimeter of the path.

Give your answer correct to one decimal place.

..... m

(Total for Question 13 is 3 marks)

14 The people working for a company work in Team A or in Team B.
number of people in Team A : number of people in Team B = 3 : 4

$\frac{4}{5}$ of Team A work full time.

24% of Team B work full time.

Work out what fraction of the people working for the company work full time.
Give your fraction in its simplest form.

.....
(Total for Question 14 is 3 marks)

15 The diagram shows a container for water in the shape of a prism.

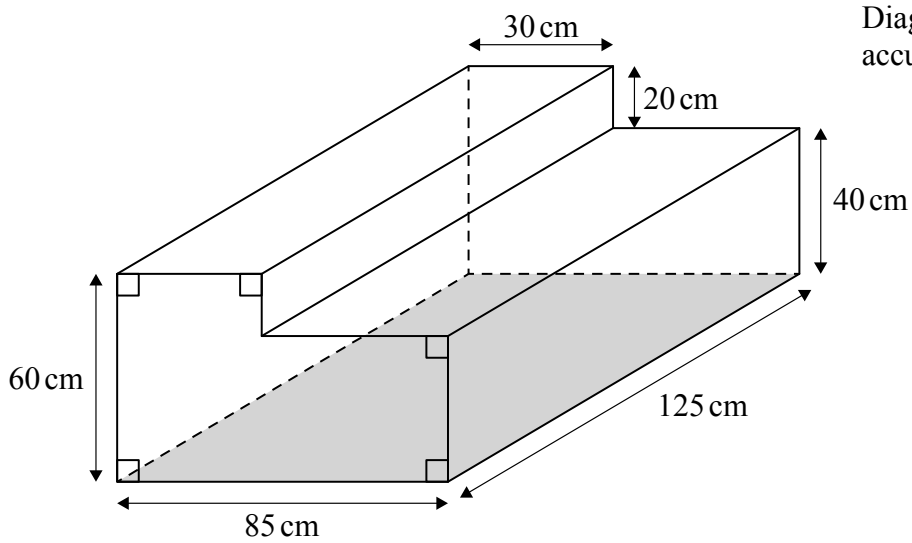

The rectangular base of the prism, shown shaded in the diagram, is horizontal.
The container is completely full of water.

Tuah is going to use a pump to empty the water from the container so that the volume of water in the container decreases at a constant rate.

The pump starts to empty water from the container at 10 30 and at 12 00 the water level in the container has dropped by 20 cm.

Find the time at which all the water has been pumped out of the container.

.....
(Total for Question 15 is 4 marks)

16 The diagram shows the positions of three ships, A , B and C .

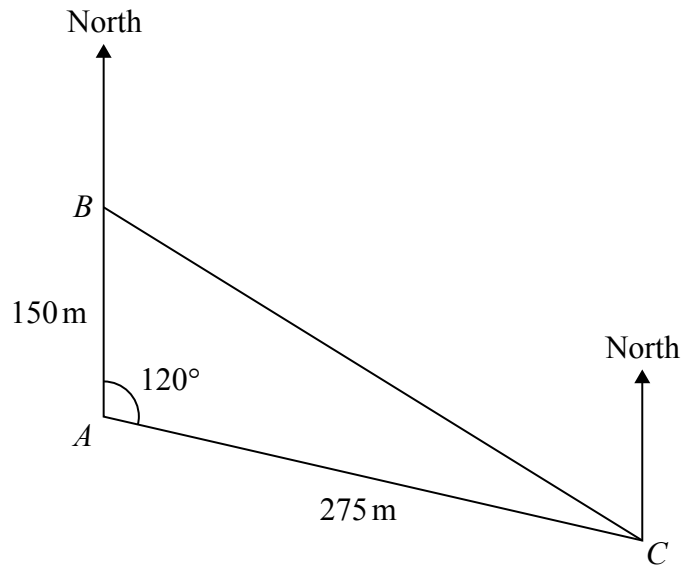

Diagram **NOT**
accurately drawn

Ship B is due north of ship A .

The bearing of ship C from ship A is 120°

Calculate the bearing of ship C from ship B .

Give your answer correct to the nearest degree.

.....°
(Total for Question 16 is 5 marks)

17 A postman records the weight of each parcel that he delivers.

The histogram shows information about the weights of all the parcels that the postman delivered last Monday. No parcels weighed more than 6 kg.

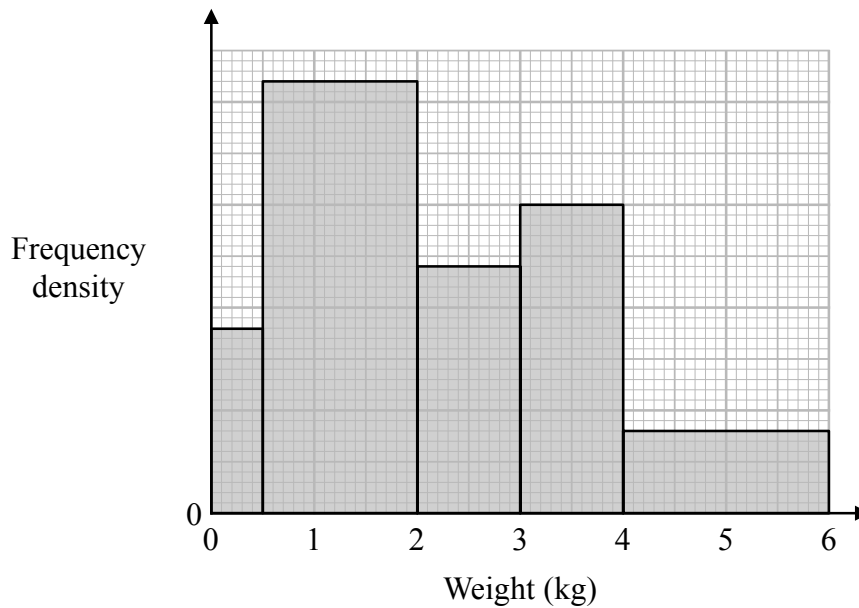

63 of the parcels that the postman delivered last Monday each had a weight between 0.5 kg and 2 kg.

(a) Work out the total number of parcels the postman delivered last Monday.

.....
(3)

The postman picks at random two of the records of the parcels he delivered last Monday.

(b) Work out an estimate for the probability that each parcel weighed more than 2.25 kg.

.....
(3)

(Total for Question 17 is 6 marks)

18 **A** and **B** are two similar solids.

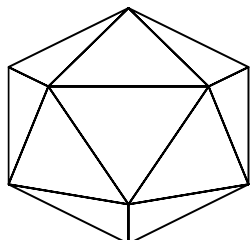

A

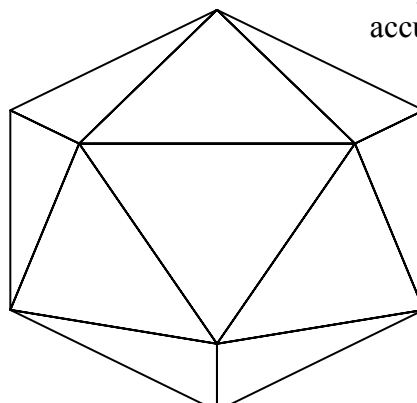

B

Diagram **NOT**
accurately drawn

A has a volume of 1836 cm^3

B has a volume of 4352 cm^3

B has a total surface area of 1120 cm^2

Work out the total surface area of **A**.

..... cm^2

(Total for Question 18 is 3 marks)

- 19 The diagram shows a sector OBC of a circle with centre O and radius $(6 + x)$ cm.

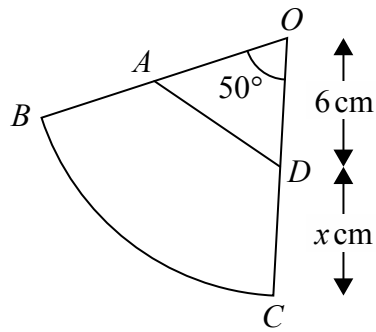

Diagram **NOT**
accurately drawn

A is the point on OB and D is the point on OC such that $OA = OD = 6$ cm

Angle $BOC = 50^\circ$

Given that

the perimeter of sector $OBC = 2 \times$ the perimeter of triangle OAD

find the value of x .

Give your answer correct to 3 significant figures.

$x =$

(Total for Question 19 is 6 marks)

TOTAL FOR PAPER IS 80 MARKS

BLANK PAGE